

Quick-Mount Ceiling Loudspeaker

Public Address Series

Ø7.09" x H4.76"
2.87 lbs



Q C M - 5 0 6 1

- ✓ 100 Hours Life Tested
- ✓ CE Certified (EMC & LVD)
- ✓ EASE Data
- ✓ RoHS Compliance
- ✓ Withstanding/Insulation Tested

Side



- Fitted with a 5.25" twin cone driver unit. Designed to offer wide response for music & speech.
- Dished grille design for acoustic integrity. Finished in white.

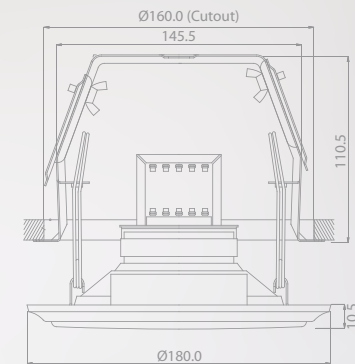

SPECIFICATION

Rated Power (rms)	6W
Impedance	1.67kΩ, 3.33kΩ, 6.67kΩ & 13.33kΩ
Power Taps @ 100V	6W, 3W, 1.5W & 0.75W
Power Taps @ 70V	3W, 1.5W, 0.75W & 0.375W
SPL (1W / 1m)	92dB
Max. SPL (Rated W / 1m)	99dB
Frequency Range (-10dB)	100 Hz ~ 20k Hz
Dispersion 1k Hz / 4k Hz	140° / 70°
Operating Temperature	-30° C ~ +60° C
Power Selection	Plug
Material	Baffle: Steel, Grille: Steel
Colour / Finish	White
Dimensions	Dia. 180 X H 121 mm
Cutout Size	Dia. 160 mm
Net Weight (ea)	1.30 kg
Mounting	Spring loaded Quick-Mount bracket assembly